

New Resilient Channel Profile P/N 581

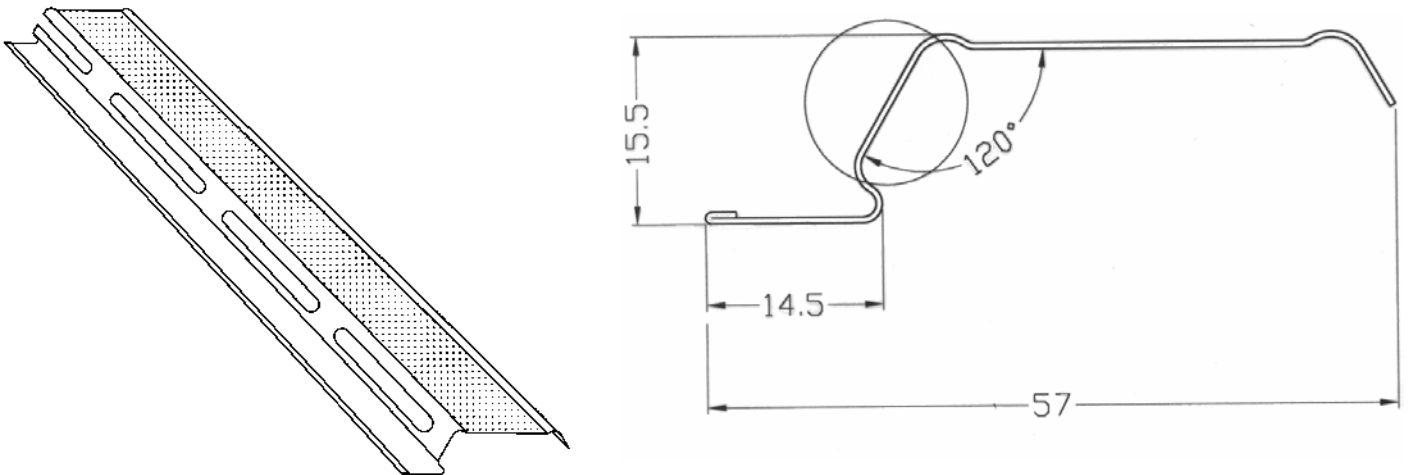

As part of Rondo's continuous improvement program, part No. 581 resilient channel has been re-engineered with some subtle, but very beneficial modifications.

The new profile which has been designed, tested, and manufactured in Australia, based on Rondo's international experience, has been tested by National Acoustic Laboratories to a STC rating of 51*. This high level of sound absorption is achieved by "floating" the plasterboard away from the studs and joists providing a low cost, highly efficient, sound insulating system for plasterboard walls, and floor /ceilings. The Rondo Resilient channel can be attached to either timber or steel studs, or to masonry walls. It can be attached to ceiling joists in floor /ceiling construction.

These changes have been based on extensive research & development within the market and overseas to determine what Rondo could do to further enhance the benefits of our already successful resilient channel. We at Rondo appreciate your input, and encourage any comments that you may have (good or bad) about any of our products or systems.

* using 2 x 16 mm plasterboard on 1 side, 1x 16mm plasterboard on the other.

RESILIENT CHANNEL SPACING AT FLOOR & CEILING LEVEL

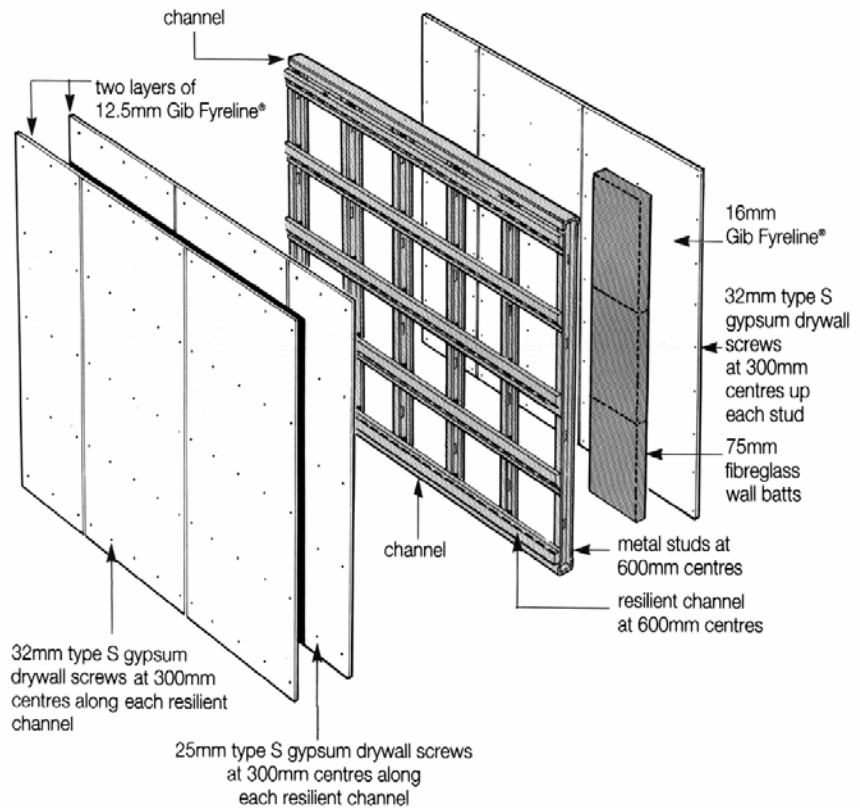
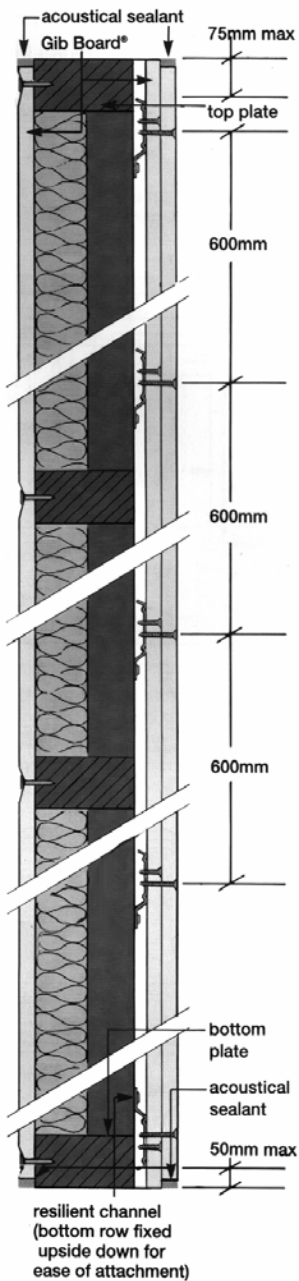

Installation Details

Partitions

- Position Rondo Resilient channels at right angles to studs at 600 mm centres max.
- Position channel so that pre-punched flange faces up.
- Use 25 mm type "S" screws through the pre-punched holes to fasten the channels to the studs.
- Fasten the channel to the stud at each intersection.
- Locate bottom channel 13 mm up from floor and top channel to suit wall set out.
- Extend channels into all corners and fasten to corner framing.
- Channels are joined by splicing together directly over the studs.
- Position building board sheets vertically.
- Screw fix and joint sheets in the normal manner.
- Perimeter gaps should be caulked for best sound results.

Ceilings

- Position resilient channels at right angles to joists spaced at 600 mm max. centres
- Space channels at 450 mm centres maximum for 10 mm thick plasterboard and 600 mm centres max. for 13 mm and 16 mm thick plasterboard.
- Use 25 mm type "S" screws through the pre-punched holes to fasten channels to joists.
- Fasten channels to joists at each intersection.
- Do not use nails to fix channels to joists.
- Fasten channels into all corners and fasten to corner framing.
- Do not cantilever channels more than 150 mm.
- Channels are joined by splicing together directly under a joist.
- Position plasterboard sheets at right angles to resilient channels.
- Screw fix and joint sheets in the normal manner.

